

EZ∞RD

by PHOENIX MECANO

INSTRUCTION MANUAL

Electric Bicycle Lift



EZ∞RD Cargo Bikelift

01	Introduction	4
01.1	Content.....	4
01.2	Intended use.....	4
01.3	Improper use	5
01.4	CE Declaration of Conformity.....	5
01.5	User Responsibility.....	6
01.6	Warning Symbols Used in this Instruction Manual	6
01.7	Types of Warning Symbols	6
01.8	Application of Symbols	7
02	Safety.....	8
02.1	Authorised Personnel	8
02.2	General Safety Recommendations	9
02.3	Personal Protective Equipment (PPE).....	10
02.4	Residual risks	10
02.5	Safety Measures Integrated into the Lift.....	10
03	Product Information.....	11
03.1	Description of the Ezoord Bicycle Lift.....	11
03.2	Technical Specifications	12
03.3	Overall Dimensions	13
03.4	Work Area	14
04	Transport.....	15
04.1	Transport	15
04.2	Unpacking	15
04.3	Unpacking Procedure	16
05	Installation.....	16
05.1	Installation	16
05.2	Dismantling and Disposal.....	17
06	Operating Instructions	18
06.1	Connection to the Power Supply	18
06.2	Use of the Controls	18
06.3	Display Control Unit	19

06.4	Clamp Rotation Control	19
06.5	Control Symbols	20
06.6	Control Functions	21
06.7	Display Messages	23
06.8	ISP (Intelligent System Protection).....	23
06.9	Operating Principle of the ISP System.....	24
07	Manual Clamping Height Adjustment.....	25
08	The Clamp	26
08.1	Main Components of the Clamp.....	26
08.2	Securing a Bicycle	28
09	Working with the Bicycle at Height	30
09.1	Moving the Lift on its Wheels	30
10	Battery	31
10.1	Restrictions of Use	31
10.2	Important Features	32
10.3	Battery Connection and Disconnection.....	33
10.4	Battery Charging.....	35
10.5	External Charger.....	36
10.6	PD15 Power Supply.....	37
11	Battery Disposal.....	38
12	Maintenance	38
13	Spare Parts.....	39

01 Introduction

01.1 Content

This instruction manual contains important information regarding the safety, installation, operation, maintenance and disposal of the **EZOORD Cargo Bikelift**.

The purpose of this manual is to ensure safe, correct and intended use of the equipment, and to inform the user about residual risks that cannot be eliminated through design measures.

This manual forms an integral part of the product and must be kept for the entire service life of the equipment.

It is recommended to always consult the most recent version available at: www.ezoord.com

	<p>WARNING! Read this instruction manual carefully before operating the bicycle lift. Failure to comply with the safety and operating instructions described in this manual may result in personal injury, material damage or malfunction of the equipment.</p>
--	--

01.2 Intended use

The **EZOORD** Cargo Bikelift has been exclusively designed as a workstation for lifting, clamping and handling bicycles, including heavy bicycles such as cargo bikes, in order to perform the following tasks:

- Maintenance
- Assembly
- Repair
- Adjustment and inspection

The lift is intended for professional or comparable environments, indoors, and under the environmental conditions specified in this manual.

Any use other than that described above shall be considered improper use.

01.3 Improper use

- The following actions are expressly prohibited:
- Lifting persons.
- Climbing, hanging or leaning on the equipment.
- Lifting loads other than bicycles.
- Modifying the equipment or its safety systems.
- Operating the lift under non-permitted environmental conditions.

	<p>WARNING! Improper use of the lift may lead to serious hazardous situations and voids the warranty and CE marking</p>
---	--

01.4 CE Declaration of Conformity

The company:

SISTEMAS PHOENIX MECANO ESPAÑA, S.A.

C/ Tarento, N°15

50197 - Zaragoza

SPAIN

Tel: +34 976 786 080

Hereby declares, under its sole responsibility that the machine:

Type: Bicycle Lift

Model: CARGO BIKELIFT

Serial No.:

Year of manufacture:

Complies with all applicable provisions of the following Directives:

- 2006/42/EC - Machinery Directive
- 2014/30/EU - Electromagnetic Compatibility Directive

Harmonised standard applied:

- EN ISO 12100 - Safety of machinery. General principles for design. Risk assessment and risk reduction.

01.5 User Responsibility

The user is responsible for:

- Reading and fully understanding this manual before first use.
- Using the lift only in accordance with the instructions described herein.
- Ensuring that only authorised, qualified and legally competent persons operate the equipment.
- Maintaining the lift in good working condition.
- Complying with applicable occupational health and safety regulations.



01.6 Warning Symbols Used in this Instruction Manual







Correct identification and interpretation of the warning symbols used in this manual is essential to prevent accidents, avoid material damage and ensure safe operation of the bicycle lift.

All warning symbols must be strictly observed. Ignoring a warning may result in serious personal injury or damage to the equipment.

01.7 Types of Warning Symbols

The following symbols are used throughout this manual to highlight different types of hazards or important information:

<i>Símbolos utilizados en el manual de instrucciones</i>	
	General Warning Indicates a potentially hazardous situation which, if not avoided, may result in personal injury.
	Warning of Material Damage Indicates a situation that may result in damage to the lift, the bicycle or the surrounding work area.
	Information Indicates important information for correct use of the equipment, without implying a direct hazard.

	Crushing Hazard Indicates a risk of crushing between moving and fixed parts of the lift during operation.
	Electrical Hazard Indicates a risk of electric shock or electrocution due to the presence of electrical voltage
	Risk of Tipping Indicates a risk of the lift tipping over, which may result in personal injury or material damage.
	Cut Hazard Indicates a risk of cuts caused by sharp edges or metallic components.
	Trip Hazard Indicates a risk of tripping over parts of the lift, such as the base or protruding elements.
	Risk of Falling Objects Indicates a risk of falling objects, including the bicycle, which may cause injury or damage.

01.8 Application of Symbols

Warning symbols appear:

- In this instruction manual.
- On labels and markings affixed directly to the lift.

	WARNING! All symbols placed on the equipment must remain legible and in good condition throughout the entire service life of the lift. If damaged or worn, they must be replaced immediately.
---	---

02 Safety

	<p>WARNING! Read and fully understand all safety instructions before operating the bicycle lift. Failure to comply with the safety instructions described in this manual may result in serious personal injury, material damage or malfunction of the equipment. The bicycle lift may only be operated when it is in perfect working condition.</p>
---	--

	<p>It is strictly prohibited to disable, modify or tamper with the safety devices and functions of the bicycle lift. Any unauthorised intervention voids the warranty and the CE marking of the equipment.</p>
---	--

02.1 Authorised Personnel

	<p>INFORMATION The bicycle lift may only be operated by authorised, qualified and legally competent persons.</p>
---	---









Authorised personnel must:

- Have read and understood this instruction manual.
- Be aware of the risks associated with the use of the lift.
- Be accustomed to applying workplace safety regulations.
- Possess the necessary physical and mental capabilities to operate the equipment safely.

The operator is responsible for their own safety and for avoiding hazardous situations during use of the lift.

02.2 General Safety Recommendations



The following recommendations must be observed during all activities carried out with the bicycle lift:

Recomendaciones	
	DANGER! Risk of electric shock due to defective electrical installation. Do not operate the lift if the electrical installation shows signs of dam-
	DANGER! Risk of electric shock due to liquid ingress. Avoid the use of liquids that may enter the interior of the lift. Do not wash bicycles while mounted on the lift.
	WARNING! Risk of cuts from sharp edges. Wear protective gloves when handling the lift.
	WARNING! Risk of tipping. Do not operate the lift on uneven, damaged or obstructed floors. Do not move the lift while it is raised.
	WARNING! Trip hazard. Pay particular attention to the base of the lift when moving around the equipment.
	WARNING! Risk of bicycle falling. Ensure that the bicycle is correctly secured with the clamp before lifting.
	WARNING! Risk of falling objects. Do not leave tools or loose objects on the lift.
	DANGER! Crushing hazard between moving and fixed parts. Ensure that no persons or obstacles are within the work area during raising or lowering movements. Do not leave the workstation while the lift is in motion.
	DANGER! Improper use of the lift. It is strictly prohibited to climb on, hang from, or lift persons with the equipment, or to use it for purposes other than those intended by the manufacturer.

02.3 Personal Protective Equipment (PPE)

	The user must apply appropriate safety measures and use the necessary personal protective equipment (PPE) in accordance with applicable occupational health and safety regulations and depending on the operations being carried out. As a minimum, the use of the following is recommended:
---	--

02.4 Residual risks

	Protective gloves against cuts and abrasions.
	Safety Footwear

Although the bicycle lift has been designed incorporating all reasonably practicable safety measures, certain residual risks cannot be completely eliminated through design.

The user can reduce these risks by strictly applying the safety measures described in this manual and by acting with due care during operation.

Hazard zones are identified on the equipment by means of warning labels.

The risk area is marked on the equipment with the corresponding warning symbol:



02.5 Safety Measures Integrated into the Lift

The **EZOORD** Cargo Bikelift incorporates the following safety measures:

- ISP system (Intelligent System Protection), which detects collisions and stops movement.
- Heavy-duty base providing stability and reducing the risk of tipping.
- Warning labels placed in hazard zones.
- Clamp design that facilitates secure clamping with the load centred.

03 Product Information

03.1 Description of the Ezoord Bicycle Lift



The **EZOORD Cargo Bikelift** has been designed as a robust, versatile and ergonomic workstation for lifting, clamping and handling bicycles during maintenance, assembly and repair operations.

It is specifically intended for handling heavy bicycles such as cargo bikes, although it may also be used with conventional bicycles and scooters, provided that the specified technical limits are respected.

The lift incorporates:

- A telescopic electric column capable of raising the bicycle to a comfortable working height.
- A rotating clamp, allowing controlled positioning of the bicycle to facilitate access to hard-to-reach areas.

The equipment is supplied fully assembled and ready for use.

	<p>WARNING! It is strictly prohibited to use the lift for purposes other than those described in this manual.</p>
	<p>WARNING! Any modification to the equipment voids the warranty and the CE marking.</p>

03.2 Technical Specifications

Figure 01.

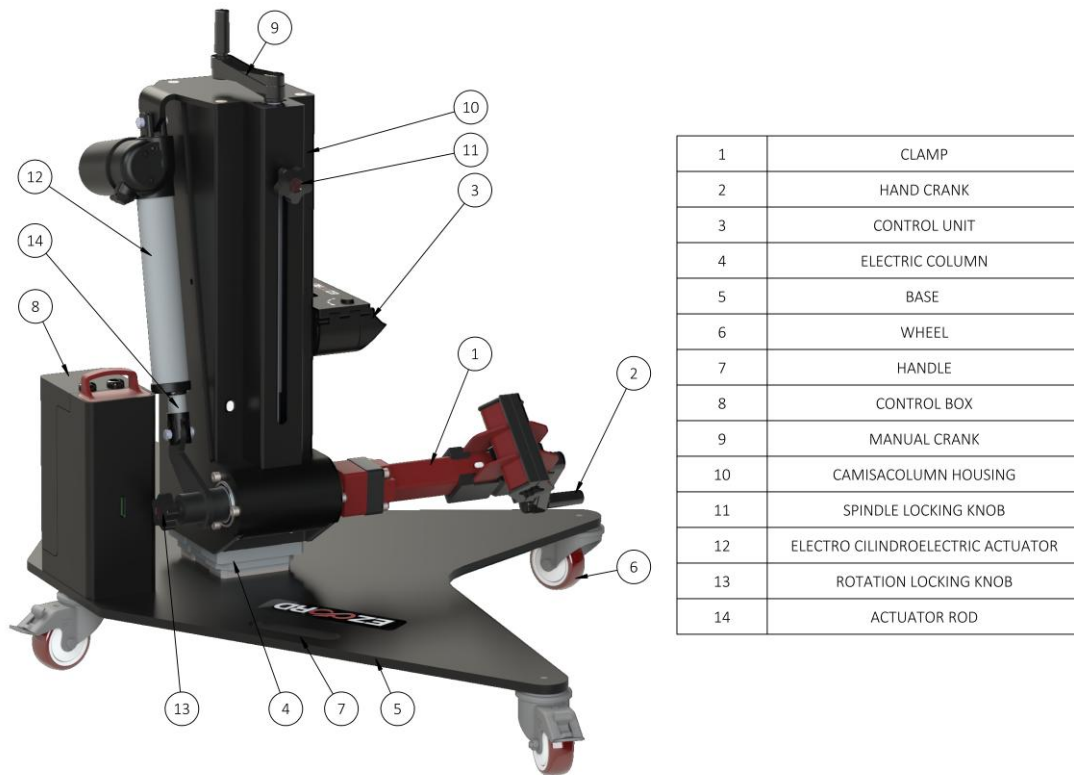

Technical Specifications	
Dimensions (Width/Depth/Height)	1310 x 820 x 805 mm
Weight	80 kg
Maximum lift (electric column)	800 mm
Minimum clamping height	180mm
Manual height adjustment	300 mm
Maximum working height (electric lift + manual adjustment)	1280mm
Lifting speed	40 mm/s
Power supply	100-240 V, 50/60Hz, 3.5A-1.6A
Installed power	0,88 kW
Telescopic column force	1000N
Temperature range	10°C - 40°C
Relative humidity	30-70 % HR
Duty cycle	2 min On /18 min Off
Battery	Li-ion 1800mAh

03.3 Overall Dimensions

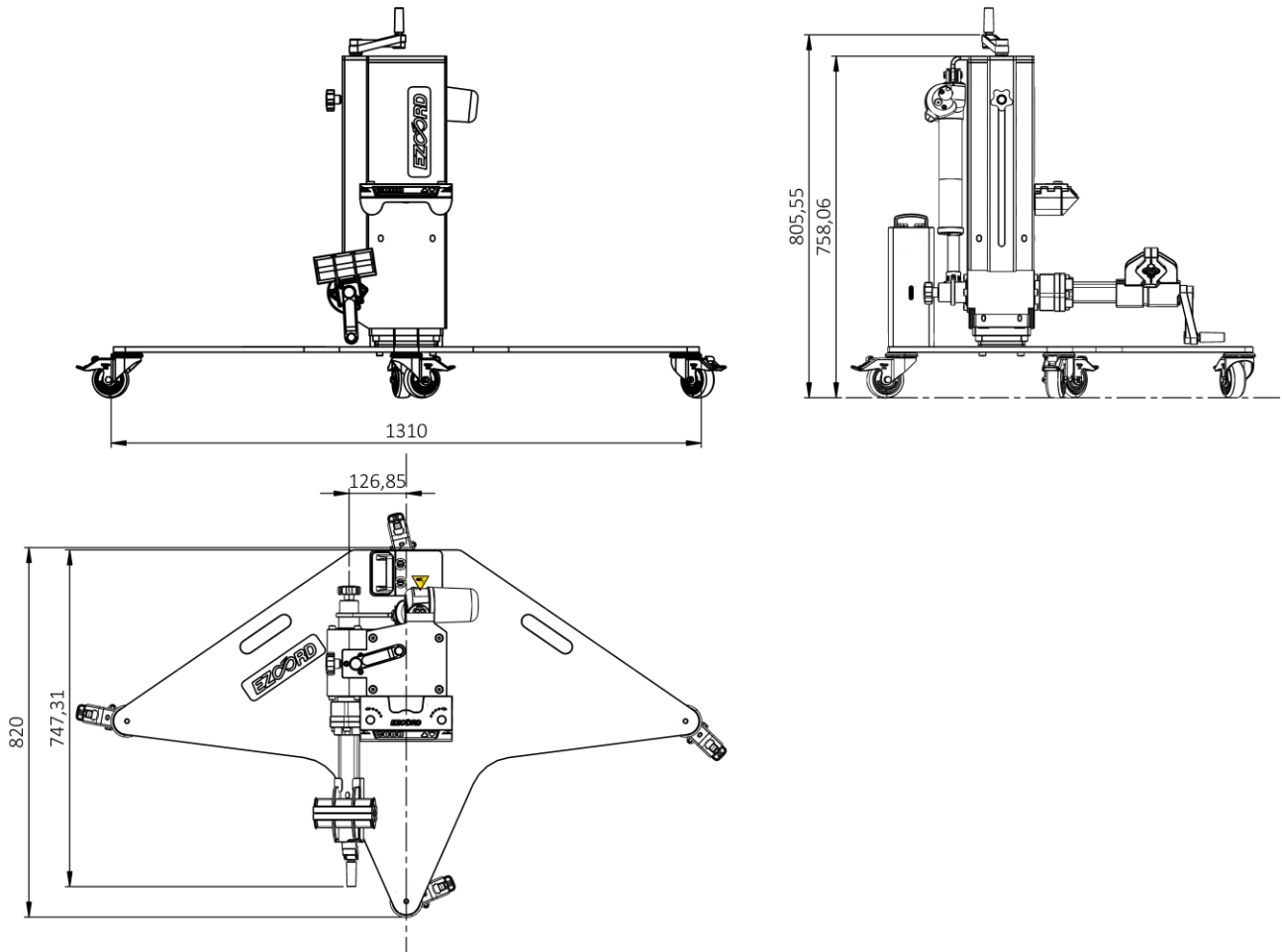

Figure 02.

03.4 Work Area

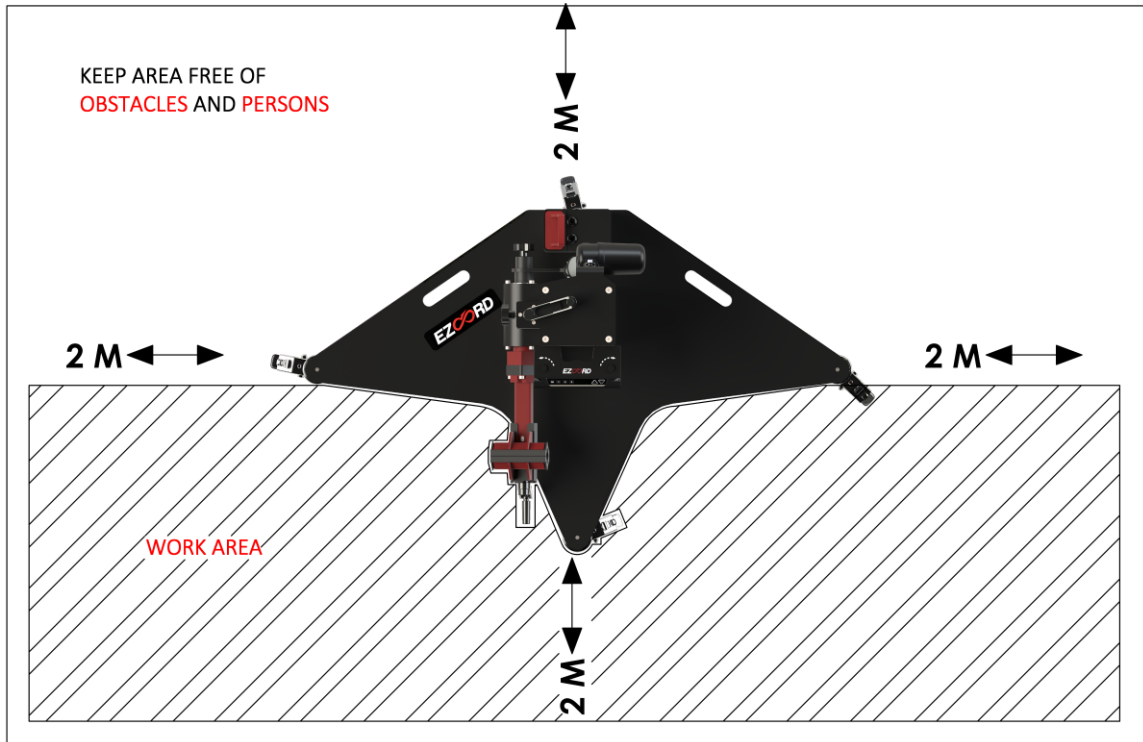

Figure 03.

To ensure safe operation of the bicycle lift, a minimum clearance of 2 metres must be maintained around the equipment, including the rear, sides and front.

	<p>WARNING! The rear area of the lift must remain free of persons and obstacles. Crushing hazard during operation.</p>
	<p>WARNING! It is prohibited to operate the raising and lowering functions if persons are present within the designated hazard zones shown in the corresponding figure. Crushing hazard.</p>
	<p>WARNING! Do not activate automatic raising or lowering functions and leave the Workstation unattended.</p>
	<p>WARNING! When moving around the lift, pay attention to the raised base of the equipment. Trip hazard.</p>

04 Transport

04.1 Transport

The **EZOORD Cargo Bikelift** is supplied packaged on a Euro-pallet and adequately protected for transport.

During transport, the following instructions must be observed:

- Use suitable handling equipment (pallet truck, forklift truck, etc.).
- Avoid impacts, drops or excessive vibrations.
- Protect the equipment from moisture, rain and excessive heat.
- Do not stack loads on top of the packaging.



	WARNING! Improper transport may cause damage to the equipment and compromise its operational safety.
--	--

04.2 Unpacking

The lift must be unpacked in a spacious, level area free of obstacles.

Before starting the unpacking process:

- Check that the packaging shows no visible signs of damage.
- Prepare the necessary personal protective equipment (PPE).
- Ensure that sufficient space is available to handle the lift safely.

	WARNING! Avoid sudden movements or unsafe handling operations during unpacking.
	WARNING! Due to the weight of the lift, unpacking must be carried out by at least two persons.

04.3 Unpacking Procedure

- Carefully remove the outer packaging materials.
- Ensure that the lift is stable on the pallet.
- Use the integrated handles on the base to lower the lift from the pallet in a controlled manner.
- Place the lift on a level and stable surface, free of obstacles.

	<p>WARNING! Do not place hands or feet under the lift while lowering it from the pallet. Risk of crushing and serious injury.</p>
---	--

Inspection After Unpacking

Once unpacked:

- Visually inspect the structure, cables and electrical components for damage.
- Verify that all warning labels are present and legible.

If any damage is detected, do not put the equipment into service and contact the manufacturer or an authorised distributor.

05 Installation

05.1 Installation

The **EZOORD Cargo Bikelift** is supplied fully assembled and ready for use.

No additional assembly operations are required prior to commissioning.

	<p>WARNING! Structural modifications, adjustments or the installation of non-authorised components are strictly prohibited. Any modification voids the warranty and the CE marking of the equipment.</p>
---	---

Before putting the lift into service, ensure that:

- The lift is positioned on a level, stable and load-bearing surface.
- No visible damage is present on the structure, cables or components.
- All warning labels are present and clearly legible.

05.2 Dismantling and Disposal

At the end of the service life of the bicycle lift, or in case of permanent de-commissioning, dismantling and disposal must be carried out in accordance with applicable environmental legislation.

General Recommendations

- Dismantling must be performed by qualified personnel.
- Separate materials according to their type:
 - Metallic components
 - Plastic components
 - Electrical and electronic components

Special attention must be given to electrical and electronic components, as well as to the battery, which must be handled in accordance with specific regulations.

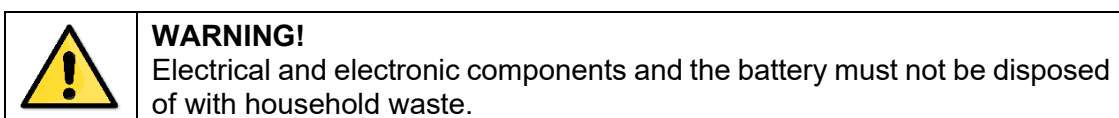

Waste materials must be delivered to an authorised waste management facility in accordance with applicable local, national and European regulations.

06 Operating Instructions

Before operating the bicycle lift, ensure that the equipment is in good condition, with no visible damage, deformation or damaged cables.

06.1 Connection to the Power Supply

Before connecting the charger:

- Place the battery charger near a properly installed power outlet.
- Ensure the outlet is equipped with protective earthing and protected by a residual current device (RCD).

Electrical Requirements

Power supply	100-240 VAC
Installed power	0,88 kW

	Note: The EZOORD lift is supplied with a power cable suitable for European outlets. No alternative plug adapter is included.
---	---

	WARNING! Risk of electric shock due to defective electrical installation. If necessary, have the outlet installed or checked by a qualified electrician.
---	---

06.2 Use of the Controls

The **EZOORD Cargo Bikelift** is operated using the following controls:

- **Display control unit**, for raising and lowering operations and memory management.
- **Rotation control**, for controlled rotation of the clamp.

06.3 Display Control Unit

The display control unit allows the operator to:

- Raise and lower the lift.
- Store working positions.
- Execute automatic movements to stored positions.
- View status and error messages.



Figure 04.

06.4 Clamp Rotation Control

The rotation control allows controlled rotation of the clamp in both directions:









- Rotation to the left.
- Rotation to the right.

The movement continues only while the corresponding button is pressed.



Figure 05.

06.5 Control Symbols

Symbol	Control Type	Function
	Display Control unit	Memory
	Display Control unit	Memory position 1
	Display Control unit	"2" Memoria 2
	Display Control unit	"3" Memoria 3
	Display Control unit	"UP"
	Display Control unit	"DOWN"
	Rotation control	"IZQUIERDA"
	Rotation control	"DERECHA"



Initial Start-Up – Manual Reset



Note:

At first start-up and after any power disconnection, a manual reset must be performed before the lift can be used.

Manual Reset Using the Display Control Unit

-  • Press and hold the "DOWN" button until the lift reaches its lowest position. If already at the lowest position, skip th step.
-  • Continue holding the "DOWN" button. The display Will alternate between "E-1" and "rEs". Release the button.
-  • Press and hold the "DOWN" button again. The lift Will move slowly downward and then briefly upward until the display shows the height value. Release the button.
- The lift is now ready for normal operation.



WARNING!

During the reset process, the ISP (Intelligent System Protection) system is inactive.

The work area must be completely free of persons and obstacles, including the bicycle, as damage may occur.

The reset must always be performed with the clamp empty.

Storing Positions Using the Display Control Unit



- Use the "UP" and "DOWN" buttons to adjust the lift to the desired height.
- Press the "M" button until "S--" appears on display.
- Press button "1". The display will alternate between "S-1" and the height value.
- Press the "M" button again to confirm memory position "1".
- Repeat the procedure for positions "2" and "3".

Factory setting:

Button **1** corresponds to the minimum height and button **3** to the maximum height. It is recommended not to modify these settings.

06.6 Control Functions

Rotating the Clamp



- Press and hold the LEFT button to rotate the clamp to the left. Release the button to stop movement.
- Press and hold the RIGHT button to rotate the clamp to the right. Release the button to stop movement.

Rising and Lowering the Lift:



- Press and hold the "UP" button to raise the lift. Release to stop movement.
- Press and hold the "DOWN" button to lower the lift. Release to stop movement.

Automatic movement:



- Press button "1". The lift moves automatically to the stored height.
- Press button "2". The lift moves automatically to the stored height.
- Press button "3". The lift moves automatically to the stored height.

	<p>DANGER! Crushing hazard between the moving column and the fixed control housing during lowering.</p>
---	--

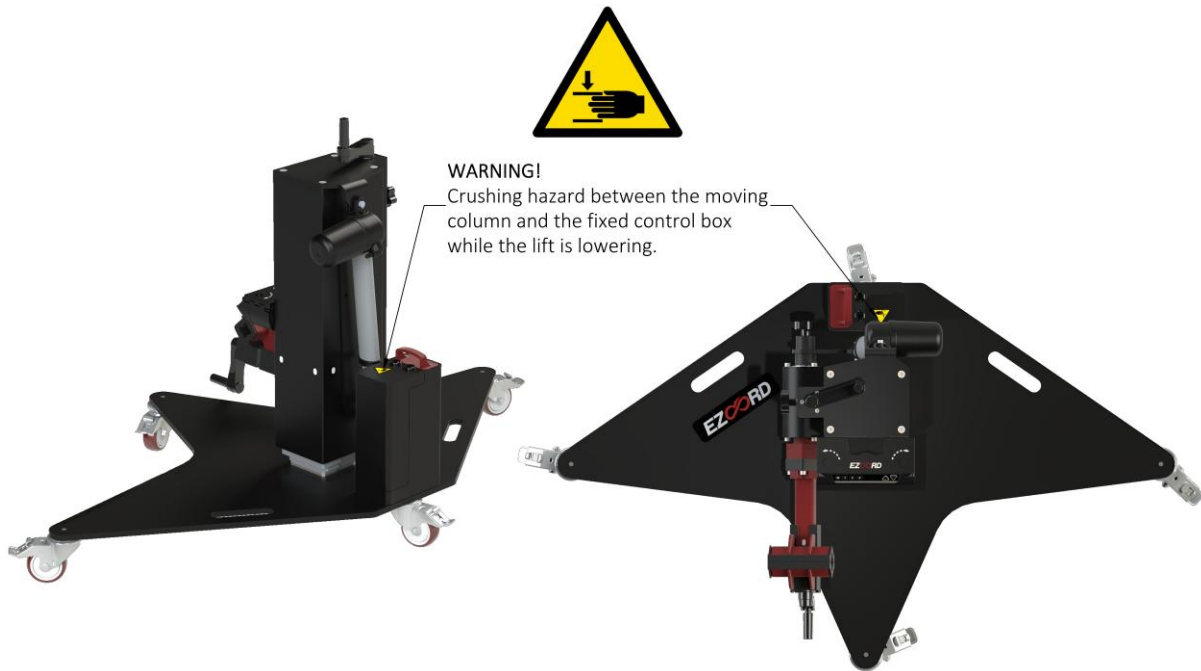



Figure 06.

Message "E-2" 

If a collision occurs during movement at nominal speed:

- The lift detects the obstacle.
- Movement stops immediately.
- The lift reverses approximately 20 mm in the opposite direction.
- The display shows message "E-2".

After removing the obstacle, normal operation can resume.

	<p>Note: The ISP function is a safety feature and must not be used as a routine operating method.</p>
---	--

Factory reset of parameters.

To restore factory settings, contact the manufacturer or authorised service personnel.

06.7 Display Messages

Código	Información	Operación
rES	Manual reset required	Complete the manual reset procedure
ovr	Overload detected	Remove excess load
E-2	ISP activated	Remove the obstacle
dut	Continuous operation longer than 2 minutes	Allow a pause of 18 minutes*.

* When pressing any button during the “**dut**” message, the remaining pause time will be displayed.

06.8 ISP (Intelligent System Protection)

The **EZOORD** Cargo Bikelift is equipped with the ISP system (Intelligent System Protection), designed to reduce the risk of crushing during lifting and lowering movements.

The ISP system monitors resistance during movement and reacts automatically in case of abnormal load or obstruction.

06.9 Operating Principle of the ISP System

If a collision occurs during upward or downward movement at nominal speed:

- The lift detects the obstacle.
- Movement stops immediately.
- The lift reverses approximately 20 mm in the opposite direction.
- The display shows message “E-2”.

Once the obstacle has been removed, the lift can be operated normally.

Important:

The ISP system is a safety feature and must not be intentionally activated during normal operation.

07 Manual Clamping Height Adjustment

The bicycle lift allows manual adjustment of the clamping height within a range of 300 mm by means of the manual crank with foldable cylindrical handle (9).

This adjustment allows adaptation of the clamping position to different bicycle types and frame geometries.

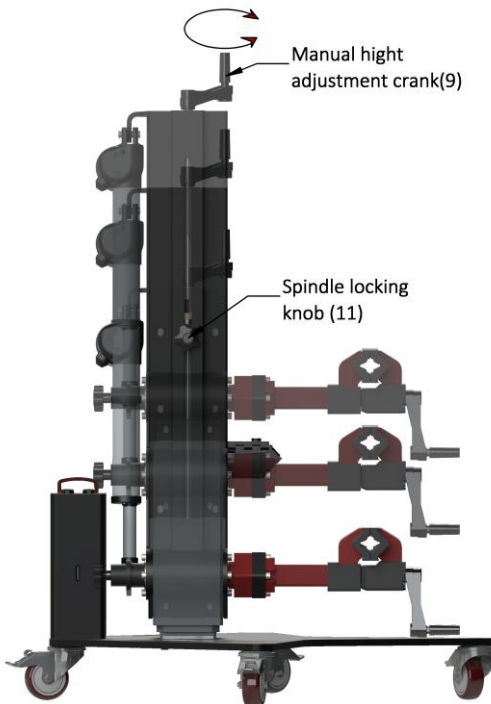

The manual height adjustment must always be carried out **without any load in the clamp** and in a controlled manner.

- **Unlock the spindle** by turning the knob (11) counterclockwise.
 - **Rotate the hand crank (9):**
 - Clockwise to lower the clamping height.
 - Counterclockwise to raise the clamping height.
 - Once the desired height is reached, **lock the spindle** by turning the knob (11) clockwise.
- Figura 07.**

	WARNING!
	When performing manual clamping height adjustment, ensure that the area beneath the clamp is completely free of persons or obstacles, including the bicycle, as damage may occur.
	This operation must always be carried out with the clamp empty and never with a bicycle mounted. When unlocking the spindle, it is recommended to hold the hand crank firmly. Otherwise, the clamp may begin to lower slowly under its own weight.

08 The Clamp

The clamp of the **EZOORD Cargo Bikelift** is designed to ensure secure, stable and controlled clamping of the bicycle frame during elevated work operations.

The clamp allows:

- Adjustment of the clamping jaws to accommodate different frame tube diameters and shapes.
- Rotation of the bicycle in both directions to facilitate access to all working areas.
- Centred load positioning to improve stability and reduce mechanical stress.

The clamp can be rotated:

- Manually, for initial alignment.
- Motorised, using the rotation control, once the bicycle is securely clamped.

08.1 Main Components of the Clamp

The clamp consists of the following functional elements:

- **Clamping jaws**, with adjustable opening.
- **Hand crank**, for opening and closing the jaws.
- **Rotation shaft locking system**, operated by lever and knob.
- **Rotation shaft**, allowing controlled rotation of the bicycle.

(Figure 08 – Figure 09)



Figure 08.

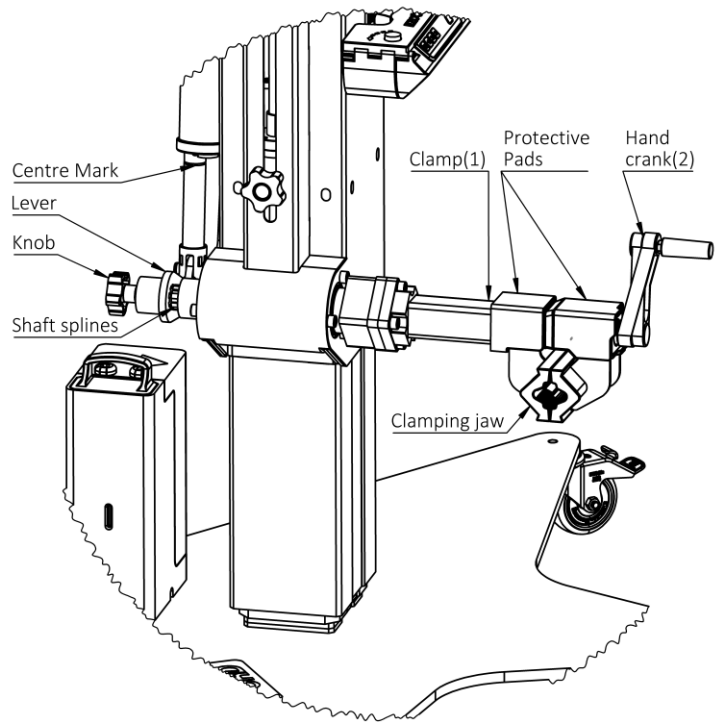

Figure 09.

08.2 Securing a Bicycle

Correct clamping of the bicycle is essential for safe operation. Before lifting the bicycle, ensure that the clamp is properly adjusted and securely locked.

Initial Clamp Alignment

Rotate the clamp to align the clamping jaws with the section of the frame to be secured.

1. Centre Positioning

Align the centring mark on the shaft with the Edge of the cylinder so that the rotational travel is equal in both directions.

2. Releasing the lever

Loosen the knob by turning it counterclockwise to create approximately **10mm** of clearance.

3. Unlocking the Rotational Shaft

Pull the lever to release the splined shaft and allow free rotation of the clamp.

4. Positioning the ClampShaft

Rotate the clamp to the desired position according of the frame geometry.

5. Locking the Rotation Shaft

Reinsert the lever into the shaft splines and tighten the knob clockwise until firmly locked.

6. Opening the Clamping Jaws

Opening the jaws by turning the hand crank counterclockwise.

Do not exceed the maximum opening range of 100mm.

7. Positioning on the frame

Move the lift towards the bicycle and position the clamping jaws around the selected section of the frame.

8. Closing the Clamping Jaws



Close the jaws by turning the hand crank until a firm grip is achieved. The clamping pressure must be adjusted by the user to ensure secure holding without damaging thin-walled frame tubes.

9. Initial Lift Test

Slightly raise the bicycle to verify stability and proper clamping before lifting to working height.

10. Adjusting the Working Angle

Rotate the bicycle using the rotation control until the desired working angle is achieved.



	<p>WARNING! The user is solely responsible for applying the appropriate clamping pressure. Sistemas Phoenix Mecano España, S.A. accepts no liability for damage caused by excessive or insufficient tightening.</p>
	<p>WARNING! Do not clamp the bicycle frame at its extreme ends, as this may cause instability and material damage.</p>
	<p>Note: It is recommended to clamp the frame as centrally as possible. This facilitates smoother rotation and reduces additional mechanical stress.</p>

09 Working with the Bicycle at Height

The **EZORD Cargo Bikelift** allows maintenance, assembly and repair tasks to be carried out by elevating the bicycle to an ergonomic working height.

During work at height, the following instructions must be observed:

- Ensure that the bicycle is correctly clamped and centred before starting any operation.
- Avoid excessive force or sudden movements that may shift the centre of gravity.
- Always keep the work area clean and free of obstacles.

	WARNING! Risk of tipping. Never move the lift while the bicycle is raised.
	WARNING! Risk of tipping. Do not operate the lift on uneven, damaged or obstructed floors.
	WARNING! Risk of tipping. Do not perform tasks that require sudden or unbalanced forces to be applied to the bicycle.

09.1 Moving the Lift on its Wheels

The lift is equipped with integrated wheels in the base to facilitate movement within the workshop.

Movement must always be carried out with caution and in accordance with the following rules:

- Lower the lift to its minimum height before moving it.
- Ensure that no bicycle is clamped to the lift during movement.
- Move the lift slowly and only on flat, stable surfaces.

	WARNING! Risk of tipping. Never move the lift with a bicycle raised or clamped.
---	---

10 Battery



Figura 10.





	<p>WARNING! Leaking batteries present a health hazard. Electrolyte may cause skin and eye injuries. In case of contact, rinse immediately with plenty of water and seek medical attention.</p>
	<p>WARNING! If the battery cable, connectors or housing are damaged, the battery must be taken out of service immediately and disposed of in accordance with applicable regulations. The battery must not be opened, dismantled, crushed or subjected to soldering operations. Avoid contact with water.</p>
	<p>WARNING! Use only the charger supplied by the manufacturer (PD15 power supply).</p>

10.1 Restrictions of Use

The battery must not be used in the following environments or applications:

- Areas where flammable or explosive gases or vapours may be present.
- Near open flames or other heat sources (heaters, ovens, direct sunlight).
- Systems or applications cleaned using automated washing processes.
- Humid environments or outdoors.
- As a power source for toys, games or other unintended applications.

	WARNING! Store the battery in such a way that the terminals cannot cause a short circuit.
---	---

	Note: Improper storage may reduce battery performance or cause irreversible damage.
	Note: Charge the battery immediately after delivery. In case of prolonged storage, recharge the battery every six months.
	Note: Disconnect the battery from the control unit and from the power supply if the system will not be used for an extended period.
	Note: Do not store the battery in direct sunlight.

10.2 Important Features

- Very low self-discharge rate
- Short-circuit protected
- Overcurrent protection
- Deep discharge protection
- Acoustic warning signal for low charge level
- Optical charge level indicator
- LED charging indicator:
 - Red LED: battery charging
 - Green LED: battery fully charged

Technical Data

- Lithium-ion battery (Li-Ion)
- Capacity: 1800 mAh
- Energy: 45 Wh
- Max. voltage: 30 V DC
- Output voltage: 25.2 V DC
- Max. output current: 5 A
- Acoustic signal threshold: ≤ 23 V
- Operating temperature range: 0 °C to +40 °C
- Charging time: approx. 5–8 h (depending on state of charge)
- Weight: approx. 550 g
- Approx. 300 charging cycles (depending on use and operating conditions)
- Transport/storage temperature: 0 °C to +55 °C
- Relative humidity: 20 % to 85 %
- Charging temperature: +10 °C to +40 °C

10.3 Battery Connection and Disconnection

The battery is equipped with a quick-disconnect system operated by a red handle located on the side of the battery dock (see figure).

Disconnection

Pull the red handle upward until approximately 1 cm of the red cover edge becomes visible.

Connection

Push the red handle downward until it reaches its end stop.

Disconnecting the battery significantly reduces power consumption in standby mode.



To remove the battery for charging, pull the red handle upward until the battery is completely released.

(Figure 11)





Figure 11.

10.4 Battery Charging

	<p>NOTE: For charging, the battery must be connected to the external charger and to the PD15 power supply. During charging, the battery may warm slightly due to internal chemical reactions.</p>
	<p>WARNING! If the battery becomes excessively hot during charging, the protection circuit may be defective. Immediately disconnect all cables and have the battery and power supply inspected by authorised technical personnel.</p>

- Use only the PD15 power supply.
- Approximate charging time: 5–8 hours.
- During charging, the red LED flashes.
- Once charging is complete, the system switches to standby mode and the green LED illuminates.
- When the PD15 power supply is disconnected from the mains, the green LED switches off.

Commissioning

	<p>Note: Fully charge the battery before first use to reach maximum capacity. When the green LED switches off after charging, full capacity is available.</p>
	<p>Note: The acoustic low-battery warning is active only while the lift is in motion.</p>

The battery operates optimally at ambient temperatures between 18 °C and 25 °C. Operating temperature must not exceed 40 °C.

After prolonged storage, several charge and discharge cycles may be required to restore maximum performance.

Warning Signals and Protection

Acoustic Warning Signal

Indicates that the battery charge level is very low. The battery must be recharged.

Deep Discharge Protection

The battery disconnects voltage is ≤ 22 V.

If the voltage drops below this value, the battery automatically disconnects from the system.

Once the voltage rises above the threshold again, the battery reconnects.

10.5 External Charger

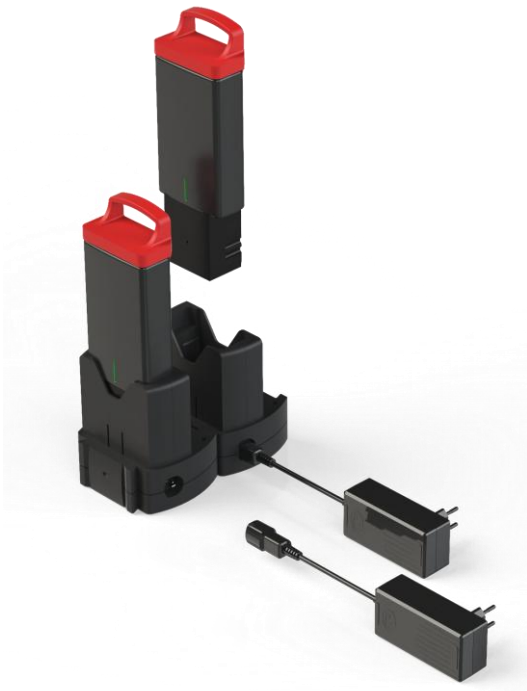

Charging Procedure

To charge the battery:

- Insert the battery into the external charger.
- Connect the PD15 transformer to a mains outlet.
- Insert the PD15 connector into the charger socket located on the side of the base.

It is possible to interconnect several external chargers to charge multiple batteries simultaneously.

Each charger must have its own power supply.

Optical Charge Level Indicator

- Flashing red LED: battery charging.
- Green LED on: battery fully charged.
- LED off: battery discharged or system in standby mode.

	<p>NOTE:</p> <ul style="list-style-type: none">• Use only approved PD15 power supplies.• Do not connect multiple chargers to a single power supply.• Do not connect or disconnect chargers with wet hands.• Do not use the charger if cables, connectors or housing show visible damage.• Ensure chargers are placed on a stable and dry surface during operation.
---	---

10.6 PD15 Power Supply

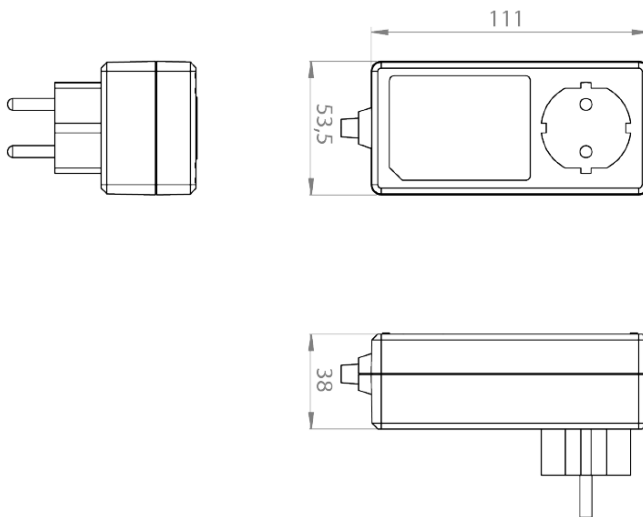

Input voltage	100-240 V50/60Hz 3.5A-1.6A
Output voltage	28V
Cable	2 POLOS
Transport/Storage temperature	-20 °C A +50 °C
Protection rating	IPX4

The PD15 power supply is connected to the charger connector in order to charge the battery.

11 Battery Disposal

The battery contains electronic components, cables and metal and plastic parts. Disposal must be carried out in accordance with applicable national and regional environmental regulations.

Disposal is regulated by Directive 2012/19/EU (WEEE) or the corresponding national legislation.

The battery must not be disposed of with household waste.

Batteries must be delivered to an authorised collection or recycling facility.

12 Maintenance

Although the **EZOORD** Cargo Bikelift is designed to be maintenance-free, certain components are subject to wear depending on frequency and intensity of use.

It is recommended to:

- Clean the equipment after each use.
- Regularly inspect the general condition of the lift.
- Ensure that all warning labels remain intact and legible.
- Check cables and visible components for signs of damage.

If defects or abnormal operation are detected, remove the lift from service and contact authorised technical personnel.

13 Spare Parts

ITEM	Code	Orders
Clamp Protective Pad	CLS04-0034	service@ezoord.com

SISTEMAS PHOENIX MECANO ESPAÑA, S.A
C/ Tarento, Nº15
50197 - Zaragoza
ESPAÑA / SPAIN
Tel: +34 976 786 080